

# Application Note

## A Hand-held Exciter for Field Mobility Measurements – an alternative to the impact hammer method

by Svend Gade and Henrik Herlufsen, Brüel & Kjær

### Abstract

This Application Note introduces a new excitation technique for exciting mechanical structures, in order to make mobility measurements. A small hand-held exciter or shaker has been developed for field measurements yielding the same advantages as those obtained using an impact hammer as well as those obtained using a shaker for the frequency response function measurements.

The main advantages are: easy to use in the field, no elaborate fixturing, and best linear approximation of system under test as well as no leakage, assuming an appropriate excitation signal has been selected. The only disadvantage is that some degree of freedom (DOF) jitter may be introduced using this method, and the use of the hand-held exciter is only applicable for relatively small structures. A complete review of advantages/disadvantages of various excitation techniques is included in this Application Note in order to put the method into the right perspective.

### Introduction

In most applications of system analysis or testing, where input-output relationships have to be measured, it is necessary to excite the system with a well controlled and measurable input. A number of different types of excitation signal are available for the analysis, each having its own advantages and disadvantages. For structural testing, for instance, it is possible to use either an impact hammer or a shaker.

If a shaker is selected, there are a number of generator signals which can be used. These are basically divided into three types, i.e., random,

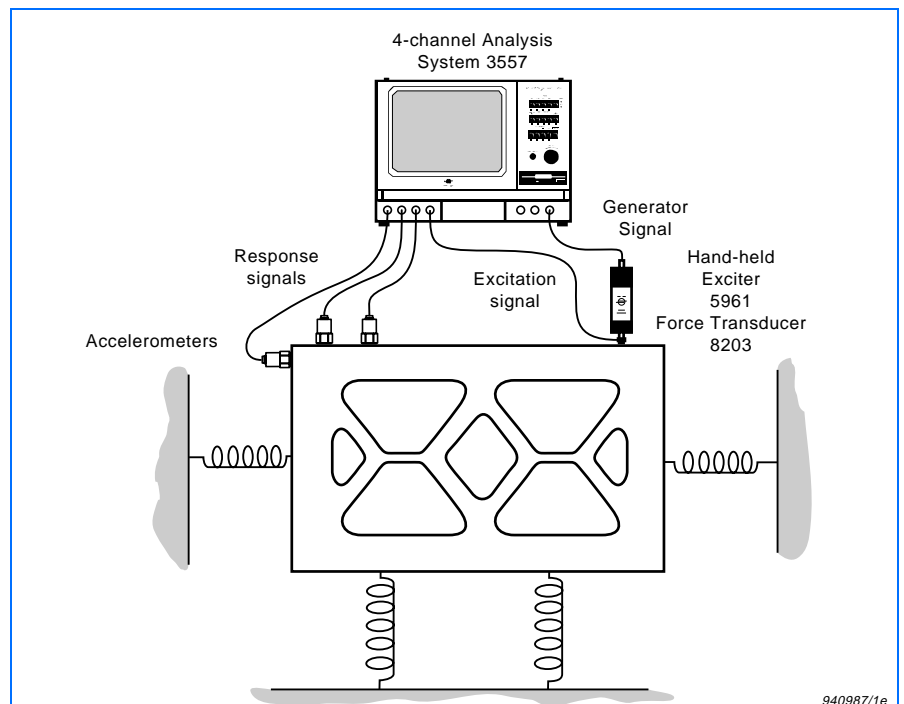

Fig.1 Complete measurement set-up using the 4-channel Analysis System Type 3557 including a generator, Hand-held Exciter Type 5961 including miniature Force Transducer Type 8203, and up to three accelerometers for measuring response signals

deterministic, or transient (impulse/impact) signals. The choice of the signal depends, among other things, upon the test application, non-linear behaviour of the system and time available for the analysis. If a hammer is selected, in fact we only have one choice, namely transient (impact) excitation, although random impact is sometimes used for zoom or low frequency measurements. The practical difference between the use of a shaker or a hammer in the field is that a shaker is normally in a fixed position and needs elaborate fixturing; while a hammer is easy to move

from measurement position to measurement position. Therefore a hand-held exciter (shaker) will bridge the gap between the two techniques. Such an exciter is easy to move from point to point and allows the use of excitation signals which are random, deterministic or transient of nature, when a versatile generator is available. Before we look at the advantages and disadvantages of the hand-held exciter we need to review the traditional techniques. In the following it is assumed that DFT/FFT analysis has been used in order to obtain frequency response estimates.

## Random Excitation

A random signal such as that shown in Fig. 2 is a continuous type of signal which never repeats itself and whose amplitude can only be predicted in terms of statistical parameters.

The main characteristic of the random excitation signal is that the spectral estimates for each recorded data block will have random amplitude and random phase. Thus, at each frequency the system can be considered as being excited by different amplitude and phase in each data block analysis. Considering the effects of non-linearities as noise at the output, the frequency response estimator  $H_1(f)$  [Ref.1] will give the best linear fit to the system or the optimum frequency response function minimizing the effects of the non-linearity (also called the least squares estimate). This is a very important advantage of random excitation. Another advantage of using random excitation is that it can be fairly easily shaped to fit the frequency range of interest by filtering and modulating the original broad band signal. Thus the system is not excited by frequencies outside the analysis bandwidth, giving a better dynamic range in the analysis. Fig. 3 gives an illustration of a baseband and a zoom measurement.

The continuous random signal does not fit the block length in the analysis. A smooth weighting function (such as the Hanning weighting) therefore has to be applied, which causes leakage in the spectral estimates [Ref.2]. This is exemplified in Fig. 4 and is one of the disadvantages of random excitation.

As a summary, the main advantage is best linear approximation of the system under test, and the main disadvantage is leakage.

## Burst Random Excitation

We can avoid the disadvantage of the random excitation by using burst random excitation i.e. gating the random signal. If both the excitation and response signals are shorter than the record length (see Fig. 5), we can apply rectangular weighting and the measurement will be leakage free (see Fig. 6).

For very lightly damped structures, special weighting functions may have to be applied [Ref.3].

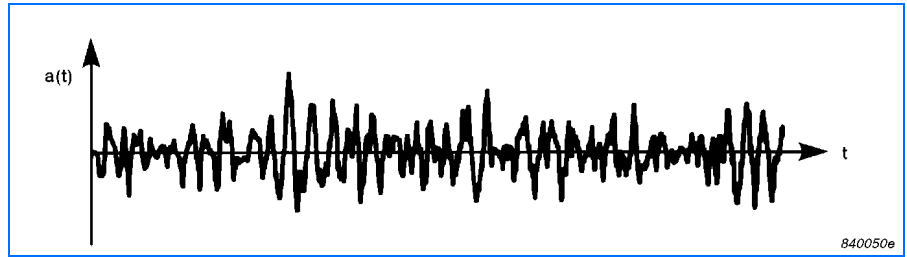

Fig. 2 Random signal

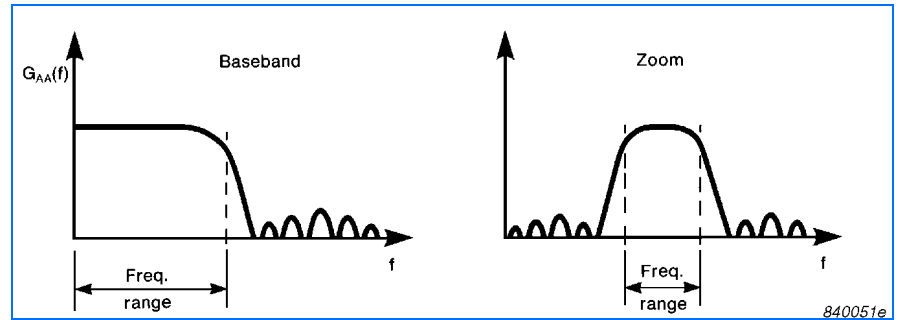

Fig. 3 Filtering of the random excitation signal giving better dynamic range in the analysis

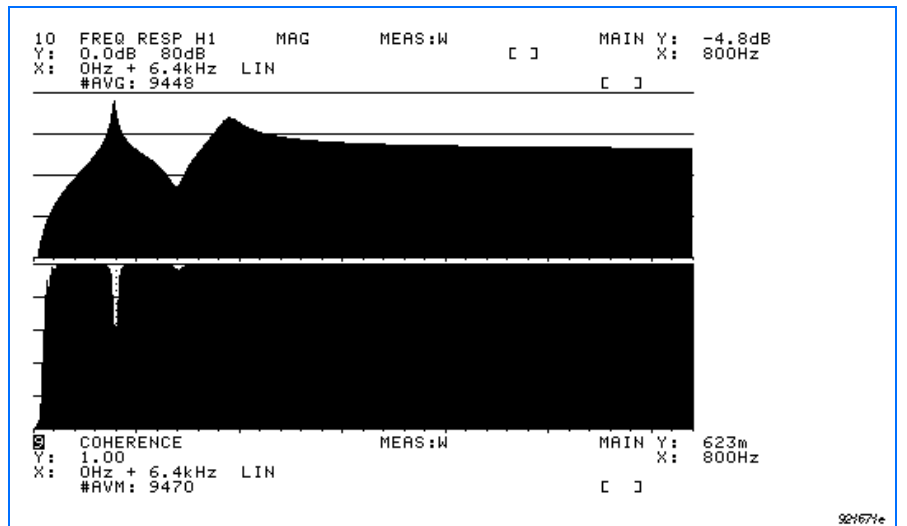

Fig. 4 Leakage indicated by a coherence lower than one at the resonance, caused by the Hanning weighting when using random excitation

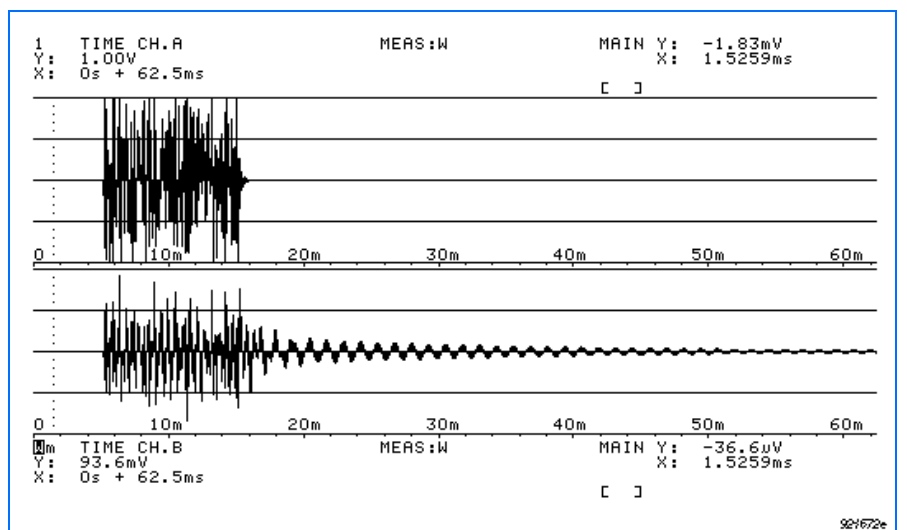

Fig. 5 Both excitation and response signals are shorter than the record length using burst random excitation

## Deterministic/Pseudo-random Excitation

The pseudo-random signal is specially designed for DFT analysis which works on blocks of data. It is made up of a segment of a random signal of length  $T$  which is repeated after every period of time  $T$ , see Fig. 7. It is periodic and therefore has energy only at discrete frequencies  $f = k/T$ , where  $T$ , is the period length and  $k$  is an integer. The period length  $T$  is matched to the record length of the analyzer, so the frequency components of the pseudo-random signals coincide with the computed frequency lines in the analyzer. One record length of the pseudo-random signal therefore contains all the information in the signal. Rectangular weighting should be used and there will be no leakage in the spectral estimates. This is probably the main advantage of using pseudo-random excitation.

The signal is designed in such a way that each frequency component has the same amplitude in the frequency range of interest. The phase angle between the different components, however, can be a random as well as a continuous curve. The pseudo-random signal can therefore also be considered as a number of sine waves, having the same amplitude and phase from measurement to measurement in the analysis frequency range, and where the time record in the analyzer contains an integer number of periods for each sine wave.

The spectrum of the pseudo-random (deterministic) signal is shown in Fig. 8. As the signals involved are deterministic and periodic only a few averages are needed in the analysis, assuming that there is no extraneous noise at the input or output. This can be an advantage especially for low frequency work and zoom analysis, compared to random noise excitation where some averaging is always needed in practice. The main advantages in using pseudo-random excitation are: no leakage in the analysis, the spectrum can be shaped to excite only frequencies in the range of interest and only a few averages are needed. The main disadvantage is that there is no linear approximation of the system under test. A measurement example is shown in Fig. 9, which shows the same level at resonance as for the burst random excitation.

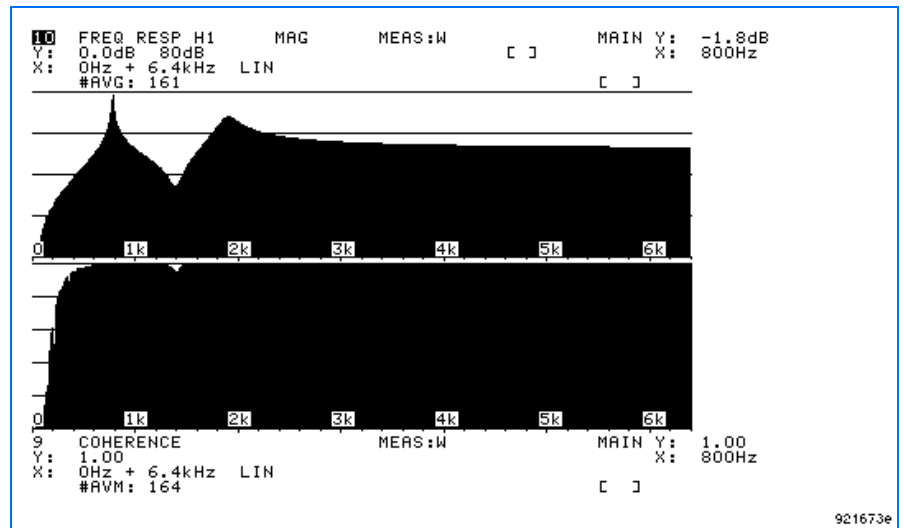

Fig. 6 Frequency response function estimation is leakage free using burst random excitation

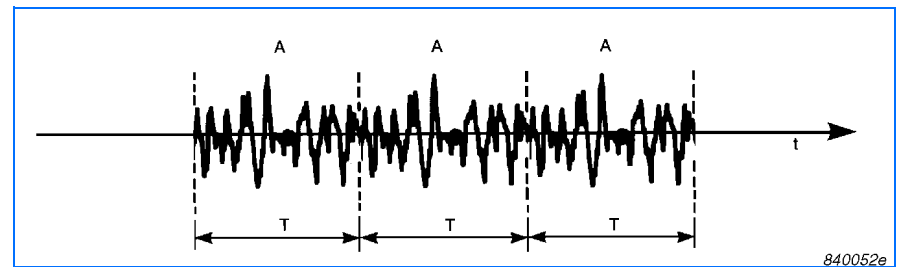

Fig. 7 Example of a pseudo-random signal

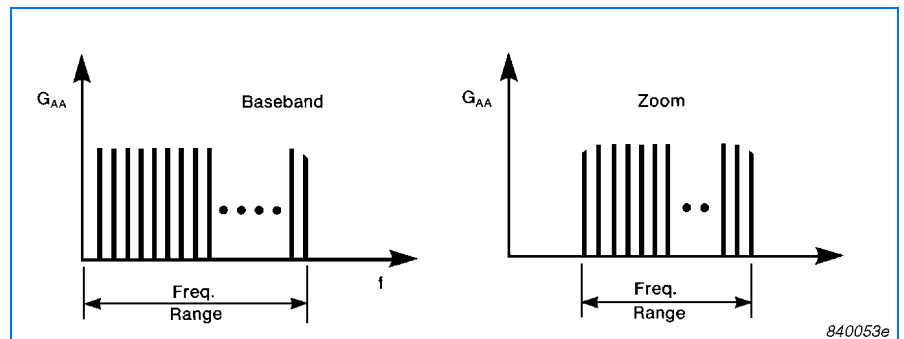

Fig. 8 Spectrum of a pseudo-random signal

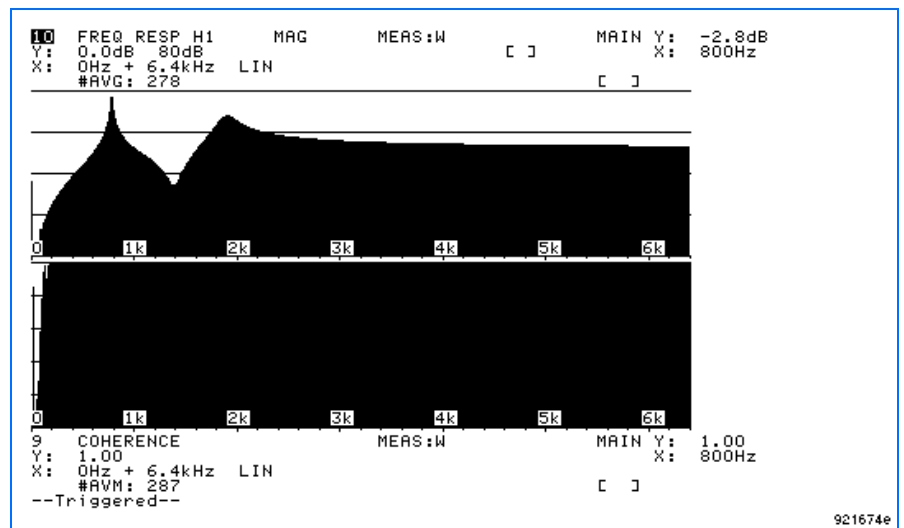

Fig. 9 Leakage free measurement using pseudo-random excitation

A special type of pseudo-random signal, where the crest factor has been minimized is the so-called multisine, where a fast sine sweep is repeated every time record,  $T$ .

## Periodic Random Excitation

We can avoid the disadvantage of pseudo-random excitation by changing the pseudo-random signal sequence with time. Such a signal is called periodic random and consists of a pseudo-random sequence (A) of length  $T$  which is repeated several times followed by another sequence (B) of length  $T$ , which is independent of A, repeated the same number of times. A third sequence (C) independent of the previous ones is now repeated and so on. As indicated in Fig. 10, the first couple of periods of each sequence are used for the transient response of the system after the change of sequence i.e. change of phase and amplitude between all the sine wave components. The last sequence is then used for the analysis where the system is in a quasi-stationary condition. Rectangular weighting should be used and there will be no leakage. In addition, it will give the best linear approximation of the system, as the different pseudo-random sequences are independent of each other (changed randomly in phase and amplitude), and each different block of signal may have different crest factor.

## Transient/Impact Excitation

A very popular and convenient excitation technique for mechanical structures is impact excitation using an impact hammer.

Fig. 11 shows an impact hammer, with a force transducer on which an impact tip is mounted. When the structure is excited by the hammer, energy is transferred to the structure in a very short period of time, giving a typical input force signal as shown in Fig. 11. The shape of this force signal depends upon the type of hammer tip, the mass of the hammer and the dynamic characteristics of the structure under investigation. As the frequency bandwidth of the force spectrum is determined by the length of the signal, these characteristics

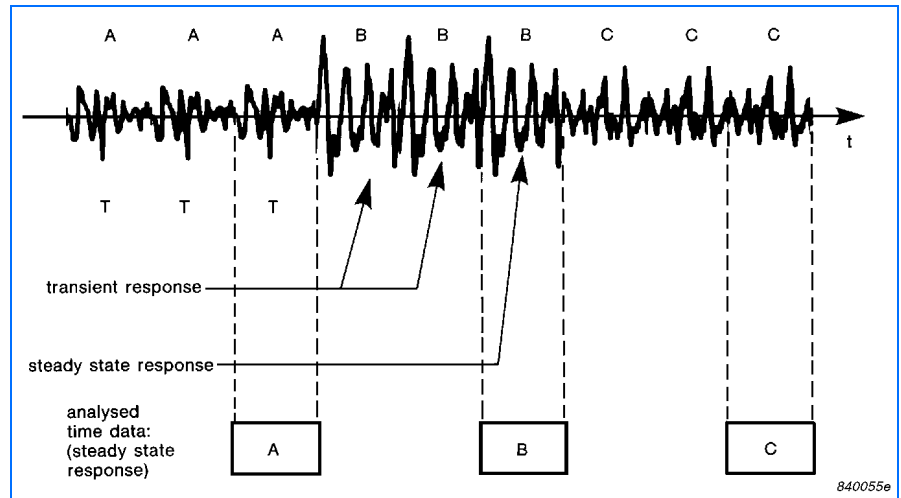

Fig. 10 Periodic random excitation signal

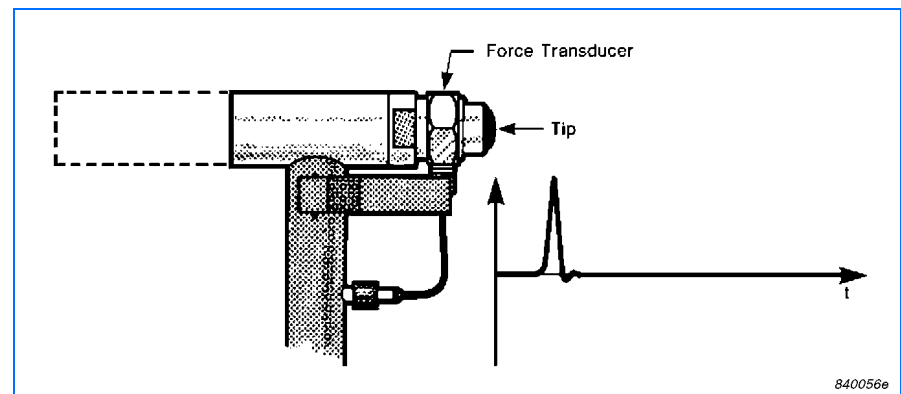

Fig. 11 Impact hammer and a typical input force pulse

will determine the upper cut-off frequency of the excitation signal. The stiffer the hammer tip and the structure are, the shorter the signal will be, and the wider the frequency span. Extra mass on the hammer, shown as dotted lines in Fig. 11, will widen the force signal and therefore lower the cut-off frequency as well as increase the excitation force level. The advantages of using impact testing are: it is very fast, only a few averages are needed, no elaborate fixturing as for shaker excitation is required, and it is easy to use in the field. However, the force signal has a high crest factor which can make this technique unsuitable for non-linear systems. The limited control of excitation bandwidth is also a disadvantage. The frequency range is always from DC to some upper frequency limit. Special weighting functions are often required giving some amount of leakage, which on the other hand can be compensated for [Refs. 2, 3].

## Hand-Held Exciter

As a consequence of all the compromises using the different excitation techniques, a small hand-held exciter (Fig. 12) has been developed, yielding the same advantages as using impact testing: no elaborate fixturing, easy to use in the field, and avoiding the main disadvantage of impact testing, the high crest factor. It features the same advantages as for normal shaker excitation that a variety of excitation signals are available so that the measurement can be made: leakage free, and the best linear approximation of the system under test can be obtained, but avoiding the main disadvantage of shaker testing, elaborate fixturing.

It should be noted that the small hand-held exciter is an alternative to the impact hammer and of course is only applicable to small structures.

## Design and Specifications of the Hand-held Exciter

The Hand-held Exciter consists of an electromagnetic exciter driven by a built-in battery-operated power amplifier. The excitation signal is fed into the exciter via the BNC-connector at the bottom. A spiralled cable with a length of 1.1 to 4 meters is supplied. The frequency range is typically up to 3.2kHz with a force rating of 0.5 N (RMS) or approximately 5 N peak. The tip is made of steel, although plastic and rubber tips can be used. The physical dimensions are a diameter of 4.5 cm and a height of 13 cm, and the weight is about 400 grams, without cables and force transducer Types 8200 and 8203 can be used, although 8203 is recommended.



Fig. 12 Hand-held Exciter Type 5961 and miniature Force Transducer Type 8203

## Measurements

Some mobility measurements have been carried out on a small lightly damped aluminium plate with the dimensions of 250·300·25 mm. All measurements have been carried out using Brüel & Kjær Multichannel Analysis System Type 3550 in a dual-channel configuration although a multichannel configuration as shown in Fig. 1 may be used. This system includes a very versatile generator, which can be synchronized with, as well as operate independent of, the FFT/DFT signal processing. A wide range of signals are available from the built-in generator in the Analysis System, such as random, burst random, pseudo-random, periodic random, multisine, etc. Force Transducer Type 8203 was used.

## Random Excitation

Measurement set-up and excitation spectrum are shown in Fig. 13, while frequency response and coherence functions are shown in Fig. 14.

Note that the excitation spectrum shows a level increase at frequencies slightly lower than the resonance frequency of the structure. That is the combined resonance of the structure and exciter transducer/tip. At the resonance we see that the excitation spectrum has a drop due to the im-

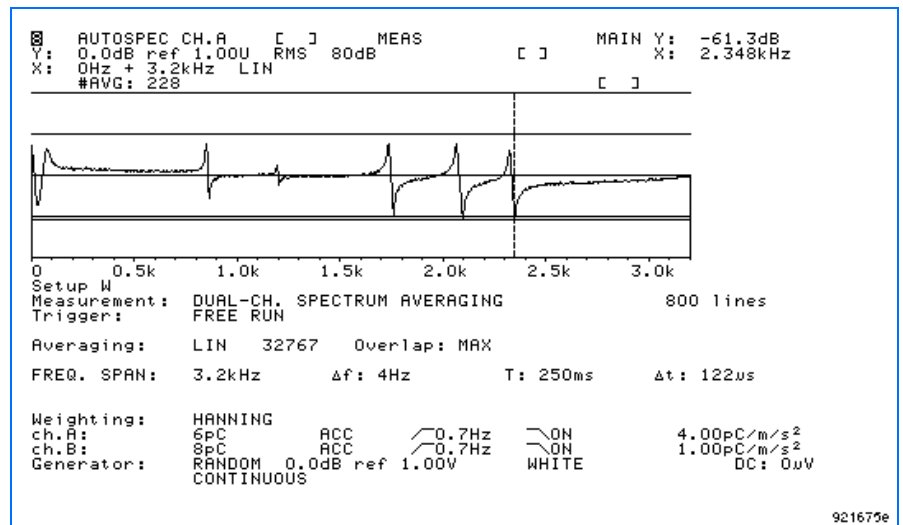

Fig. 13 Measurement set-up and input force spectrum for random excitation

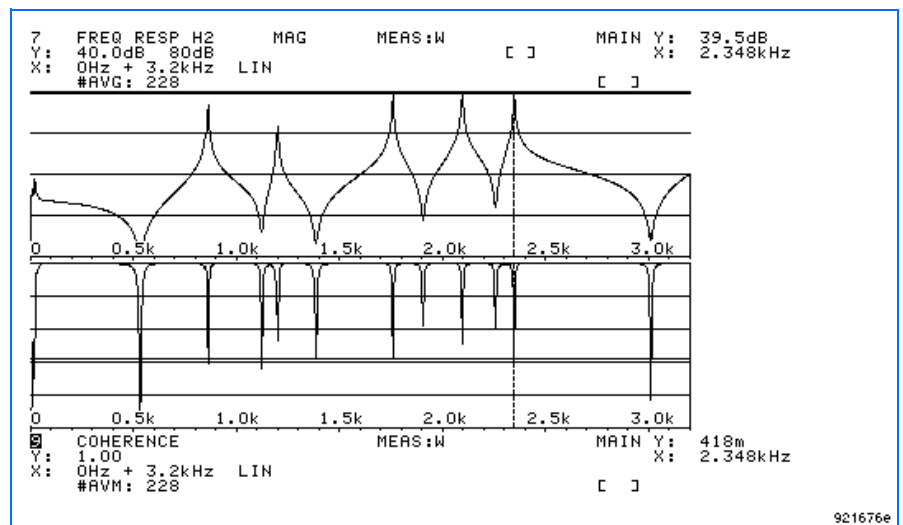

Fig. 14 Frequency response function and coherence function using random excitation

pedance mismatch between the structure and the shaker. Due to the high mobility at resonance, it is very difficult to feed a force into the structure. In this case one will probably prefer to use the  $H_2$  frequency response estimator [Ref.1]. The coherence shows the traditional low value at resonance, which is mainly due to the leakage (and to a certain extent the above-mentioned signal-to-noise problems at input). Also in the leakage case one will prefer to use  $H_2$ . One advantage compared to impact excitation is that we can band limit the excitation spectrum (zoom). This is done around the fifth resonance as shown in Figs.15 and 16. This is a feature an impact hammer does not have. Comparison between Figs.14 and 16 indicates that the  $H_2$  estimator was reasonably close to the correct result in baseband mode, where the  $H_1$  estimator had a value that differed from  $H_2$  by  $20 \log |H_1/H_2| = 20 \log \gamma^2 = 20 \log (0.418) = -7.5 \text{ dB}$ .

### Burst Random Excitation

A short burst with a duration of 10ms has been used (Fig.17). It is clear that the overall RMS level of excitation drops by approximately 20dB.

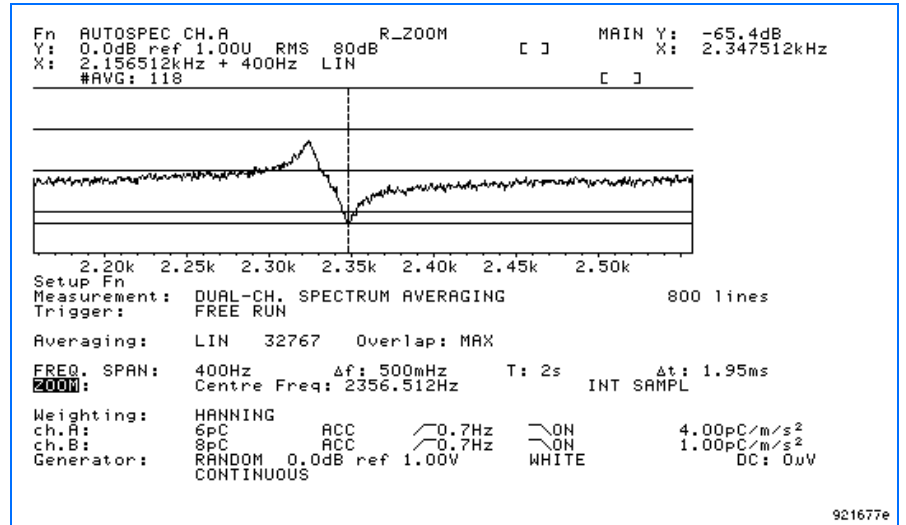

Fig. 15 Measurement set-up and input force spectrum for random excitation in zoom mode

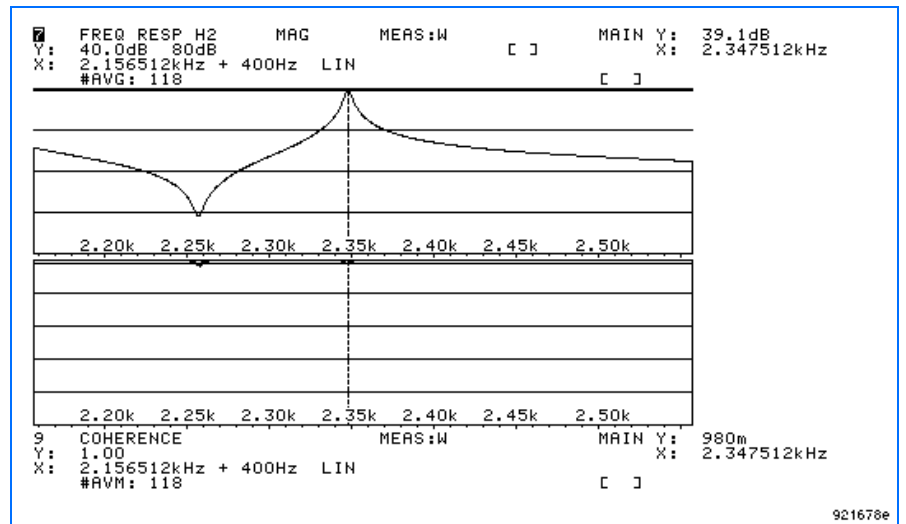

Fig. 16 Frequency response function and coherence function using random excitation in zoom mode

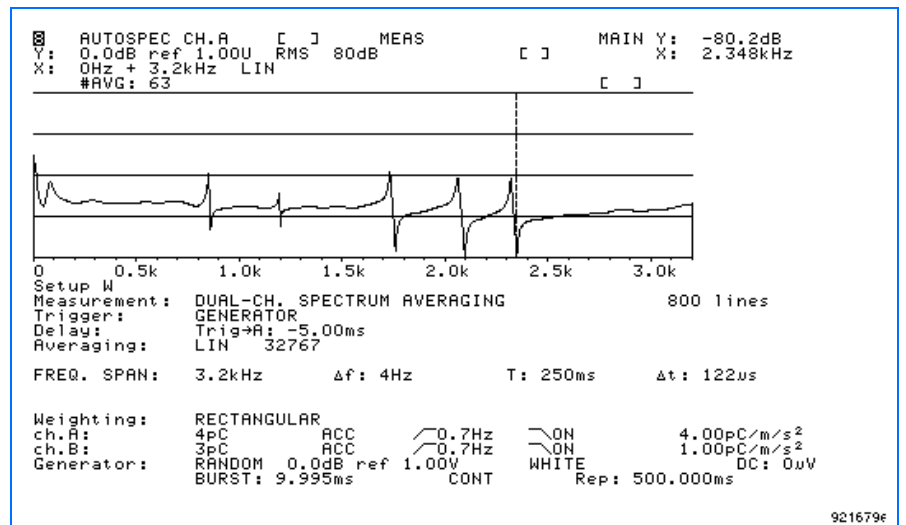

Fig. 17 Measurement set-up and input force for burst random excitation

Fig. 18 shows that the leakage phenomena is, if not eliminated, then at least heavily reduced at the resonances. Coherence is still so much lower than unity at resonances that we prefer to use the  $H_2$  estimator. Using burst random, our signal-to-noise ratio is no longer optimum, which is clearly revealed at anti-resonances, where the  $H_2$  estimator even shows some artificial resonance peaks. In these regions  $H_1$  is superior to  $H_2$ . In this case rectangular weighting was used since both excitation and response signal had a duration of the same order of magnitude as the record length.

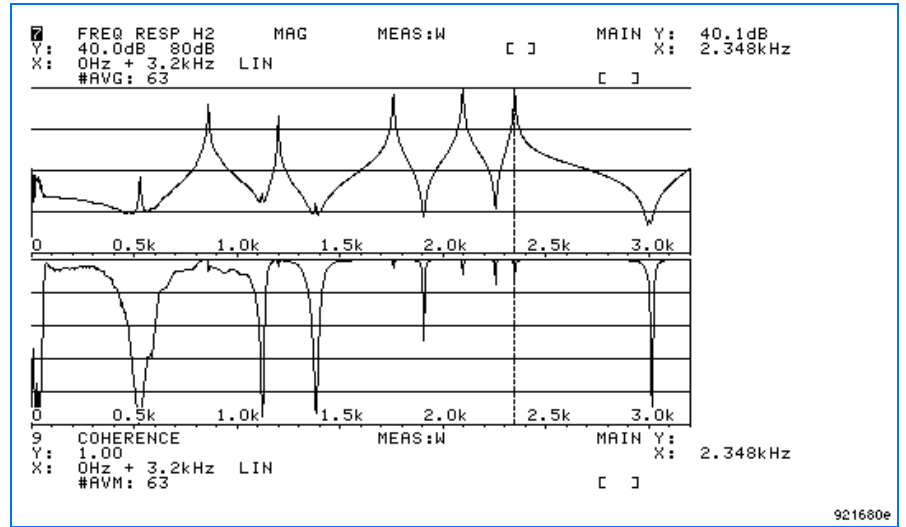

Fig. 18 Frequency response function and coherence using burst random excitation

## Pseudo-random excitation

Pseudo-random excitation has been used for the measurements shown in Figs. 19 and 20. Leakage is eliminated at resonances and any drop in the coherence at these frequencies is due to the drop in the excitation force. In our case the pseudo-random excitation was the best choice, since we also obtained an excellent signal-to-noise ratio in the measurement.

## High Mobility Structure

A structure with an extremely high mobility (light damping) has been used for better visualization of the differences of the various excitation signals.

In more practical situations we will encounter structures exhibiting more damping, making the measurements easier to perform yielding results not showing these extreme drops in the coherence functions and excitation spectra as seen through Figs. 13 to 21.

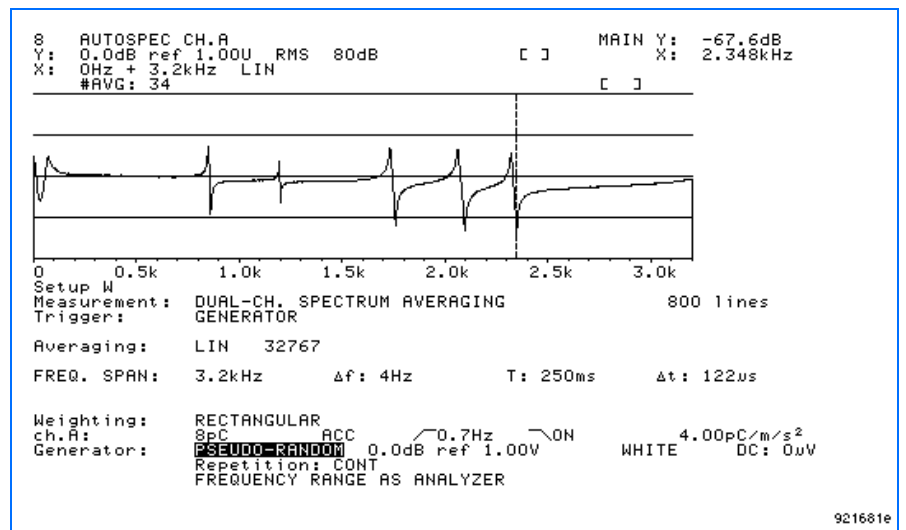

Fig. 19 Measurement set-up and input force for pseudo-random excitation

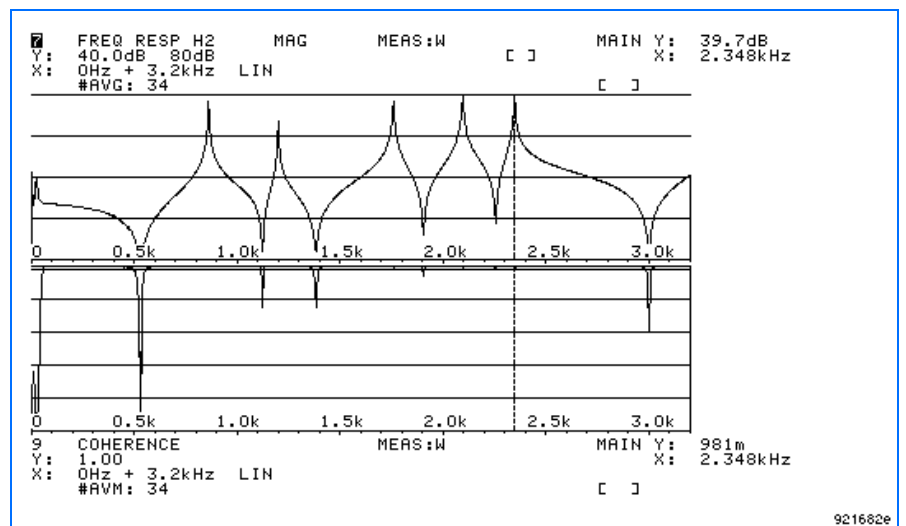

Fig. 20 Frequency response function and coherence using pseudo-random excitation

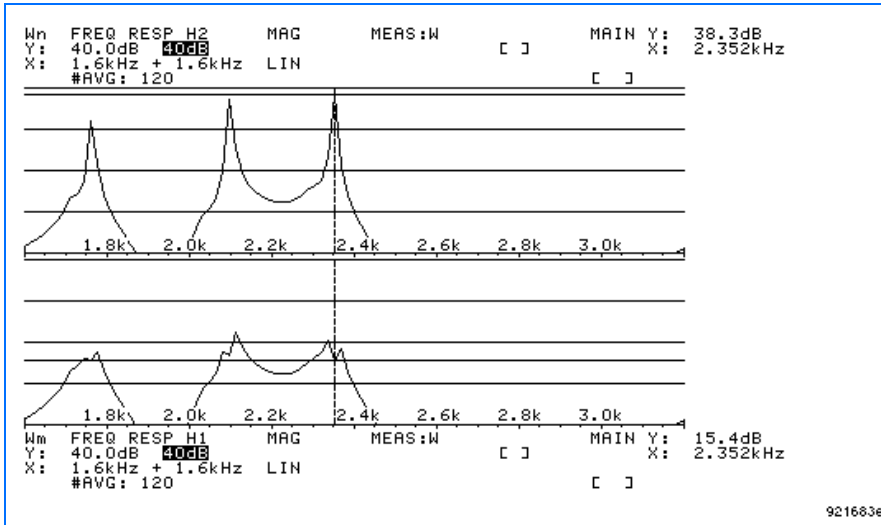

Fig. 21 Volcano effect

## Volcano effect

Another effect which is due to the high mobility at resonances is the volcano effect where  $H_1$  might even show a drop at the resonances, while  $H_2$  eliminates this problem (Fig. 21). Furthermore it seems that one cure for this problem is to apply some beeswax or silicone grease at the excitation point. This will prevent the tip from slipping on the surface. This also reduces the risk of excitation of degree of freedom jitter.

## Choice of Tips

Since the generator only outputs energy in the analysis range, there is basically no need for a choice between different tips. A tip which is stiff

(steel) and which has a small contact surface is preferable, and if the surface allows, you might even use a stud like the one shown in Fig. 22.

## Conclusion

The Hand-held Exciter Type 5961 combines the advantages of an impact hammer test and a shaker test. It gives the versatility of the shaker test for optimizing the crest factor and frequency range. This is important in cases where non-linearities in a structure could be invoked due to the high crest factor of impact excitation. The frequency range of the excitation is also optimal, as it can be set to be the same as the frequency range of analysis (including zoom). For lightly damped structures, there is a tendency that the  $H_2$  estimator

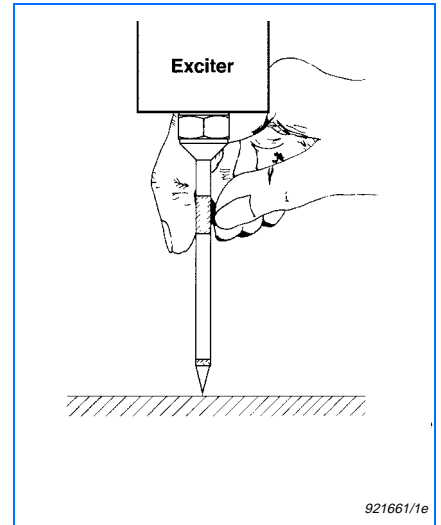

Fig. 22 A probe used as a tip for the hand-held exciter

is the best choice. The main use is for modal tests on small (and medium) size structures.

## References

- [1] Herlufsen, H.: *Dual-channel FFT Analysis (Part I & II)* B&K Technical Reviews, Nos. 1 and 2, 1984
- [2] Gade, S. and Herlufsen, H.: *Use of Weighting Functions in DFT/FFT Analysis* Brüel & Kjær Technical Reviews Nos. 3 and 4, 1987
- [3] Gade, S. and Herlufsen, H.: *Digital Filter Techniques vs FFT Techniques for Damping Measurements* Proceedings of 8th International Modal Analysis Conference, Orlando, FL, pp 1056-1064, 1990, also printed in *Sound and Vibration*, pp 24-32, March 1990.